

Standard of NICE3000 electric wiring diagram:

1. Name designation rule of power supply level.

The 3-phase 5 wires of the 380 V power which located on the preamp of the main air circuit breaker are named R',S',T',N and PE. The 3-phase 5wires which located on the backward stage of the main air breaker are named in accordance with the rule of R,S,T,N,PE.

The one of the 220 v illumination power which located on the preamp of the power cabinet air breaker is named Xa, Xb, the one on the backward stage named 501,502., for the live wire that behind these named with the rule of 501, the range is 503~510.

The control transfer primary named with the R', S', T 'rule, the secondary name designation of the control transfer: AC 220 V is 201, 202, AC 110V is 101,102 and DC 110V is D01, D02.

The input side of 24v power supply connect to 201,202; The output side named 301, 302.

2. Name designation rule of wire number.

The input signal relevant circuit of controller 24V power adopts the corresponding code as the wire number.

101-199 relevant circuit of AC 110V

201-299 relevant circuit of the control AC 220V

501-510 relevant circuit of the AC 220V illumination power

601-610 relevant circuit of AC 36V

3. switch and contact rules

All the switches, relays, and contacts are subject to the rule of UP- ON, DOWN-OFF, LEFT-ON and RIGHT-OFF.

4. The power supply of traveling cable yellow 1~10 and white 1~5 should above 36v. The white 6~10 and orange 1~10 should be 24v

5. The relay and contactor in this diagram all apply Schneider product series; the connectors are apply AMP 15 pin, 12pin, 9pin, 6pin, and 3pin as reference.

Content	
NO.	Content
1	Diagram specification and content
2	Electric codes
3	Circuit diagram of 380V power supply
4	Circuit diagram of 220V power with UPS emergency power
5	Circuit diagram of 220V power with 48V emergency power
6	Main control circuit diagram
7	Car top control circuit diagram
8	Parallel circuit diagram
9	Safety braker circuit diagram
10	Lighting circuit diagram
11	Intercom circuit diagram
12	System diagram
13	Connctor and plug-in diagram
14	Cable wiring (1)
15	Cable wiring (2)
16	Cable wiring (3)
17	Cable wiring (4)
18	Terminal diagram of travelling cable and control cabinet

1

2

3

4

5

6

7

8

Code	Position	Meaning	Code	Position	Meaning	Code	Position	Meaning	Code	Position	Meaning
1BFS	HTW	Buffer switch 1	DZD	CAR	Down leveling sensor	NSB	CAR	ATT nonstop switch	TOCLS	CAR	Car top illumination switch
2BFS	HTW	Buffer switch 2	DZU	CAR	Up leveling sensor	OLT1	HTW	Door 1 open limit	TRF1	CTR	Control transfer
AB	CAR	Alarm	EDP1	CAR	Door 1 light curtain	OLT2	HTW	Door 2 open limit	TRF2	CTR	Illumination transfer
ACB	CAR	Attendant divert button	EDP2	CAR	Door 2 light curtain	OS	HTW	Speed limiter electric switch	TRF3	CTR	Switching Mode Power supply
ALB	CAR	Alarm button	EEC	CAR	Safety window electric switch	PES1	HTW	Pit emergency stop button	TUR1	CAR	Car top AC 220V socket
ATS	CAR	ATT/AUTO switch button	EIS	CTR	Emergency electric run switch	PES2	HTW	Pit emergency stop button	TUR2	CAR	Car top AC 36V socket
BRM	CTR	Brake unit	EOR	CTR	Emergency electric run relay	PFR	CTR	PFR	UDB	CTR	Control cabinet inspection up run button
BRT	CTR	Brake resistor thermal protection switch	F	CAR	Car fan	PG	MR	Encoder (traction machine)	ULS1	HTW	1st up forced slowdown switch
BZK1	HTW	Brake feedback switch 1	FIR	CTR	Fire back to base floor output signal	PL1	HTW	Pit lighting light	ULS2	HTW	2nd up forced slowdown switch
BZK2	HTW	Brake feedback switch 2	FIRS1	HTW	Fire switch (base floor)	PLS1	HTW	Pit lighting switch 1	ULS3	HTW	3rd up slowdown switch
BUZ	CAR	Buzzer	FIRS2	CAR	Fireman switch (operation box)	PLS2	HTW	Pit lighting switch 2	UPC	CTR	Power failure emergency run contactor
BY	CTR	Brake contactor	FLSD	HTW	Down ultimate switch	PUR1	HTW	Pit socket AC 220V			
CBn	CAR	Floor command button	FLSU	HTW	Up ultimate switch	PUR2	HTW	Pit socket AC 36V			
CCB	CAR	Command allocate board	FS	CAR	Car fan switch	QF1	CTR	AC 380V air breaker			
CES	CAR	Car emergency stop switch	FX	CTR	UVW jump-out relay	QF2	CTR	DC 110V air circuit breaker			
CFL	CAR	Car emergency light	GS	CAR	Door-lock electric switch	QF3	CTR	AC 110V air circuit breaker			
CLI	CAR	Car lighting light	GTS	HTW	tensioner electric switch	QF4	CTR	AC 220V air circuit breaker			
CLIS	CAR	Car lighting switch	HCB	HTW	Floor display board	QF5	CTR	AC 36V air circuit breaker			
CLT1	CAR	Door 1 close limit	INTB	CAR	Intercom button	RGS	MR	Rope gripper switch			
CLT2	CAR	Door 2 close limit	ISS	CAR	Independent run switch	RRB	CTR	Speed limiter remote release button			
CHM	CAR	Voice landing announcer	JUP	CTR	Power failure emergency run auxiliary relay	RRD	HTW	Speed limiter remote release coil			
CTB	CAR	Car top control board	LIHn	HTW	Hoistway lighting light	RS	CTR	Forced inspection relay			
DBR	CTR	Brake resistance	LIHS	HTW	Hoistway lighting switch	RTB	CTR	Speed limiter remote action button			
DCB1	CAR	Door 1 close button	LPS	CTR	Lighting power air breaker	RTD	HTW	Speed limiter remote action coil			
DCB2	CAR	Door 2 close button	LPT	CAR	Arrival gong	SC	CTR	Safety contactor			
DDB	CTR	Control cabinet inspection down run button	LSD	HTW	Down limit switch	SOS	CTR	Safety gear electric switch			
DD0B	CAR	Door-opening delay button	LSU	HTW	Up limit switch	SW	CTR	Run contactor			
DLC	CTR	Door-lock contactor	LWD	CAR	Weighing sensor	TA	CTR	Big terminal			
DLS1	HTW	1st down running slowdown switch	LWO	CAR	Overload switch	TB	CTR	Small terminal			
DLS2	HTW	2nd down running slowdown switch	LWX	CAR	Full switch	TCI	CAR	Car top inspection auto shift switch			
DLS3	HTW	3rd down running slowdown switch	MCB	CTR	Main board	TCIB	CAR	Car top inspection share button			
DM	CAR	Door-machine motor	MES	CTR	Control cabinet emergency stop button	TCID	CAR	Car top inspection down run button	CAR	NULL	Car
DOB1	CAR	Door 1 open button	MES-2	MR	Winding switch (set emergency stop)	TCIU	CAR	Car top inspection up run button	CTR	NULL	Control cabinet
DOB2	CAR	Door 2 open button	MO	MR	Traction machine	TES	CAR	Car top emergency stop button	MR	NULL	Motor
DS	HTW	Gate-lock electric switch	MT	MR	Motor thermal protection switch	TOCL	CAR	Car top lighting light	HTW	NULL	Hoistway

Design	Gaoxiang	SDD		 Suzhou Monarch Control Technology Co.,Ltd Electric codes
CHK	Zhaoqiang			
APPD	Gaoyang		Page 2	
AUTH	Gaoxiang	Date	18	

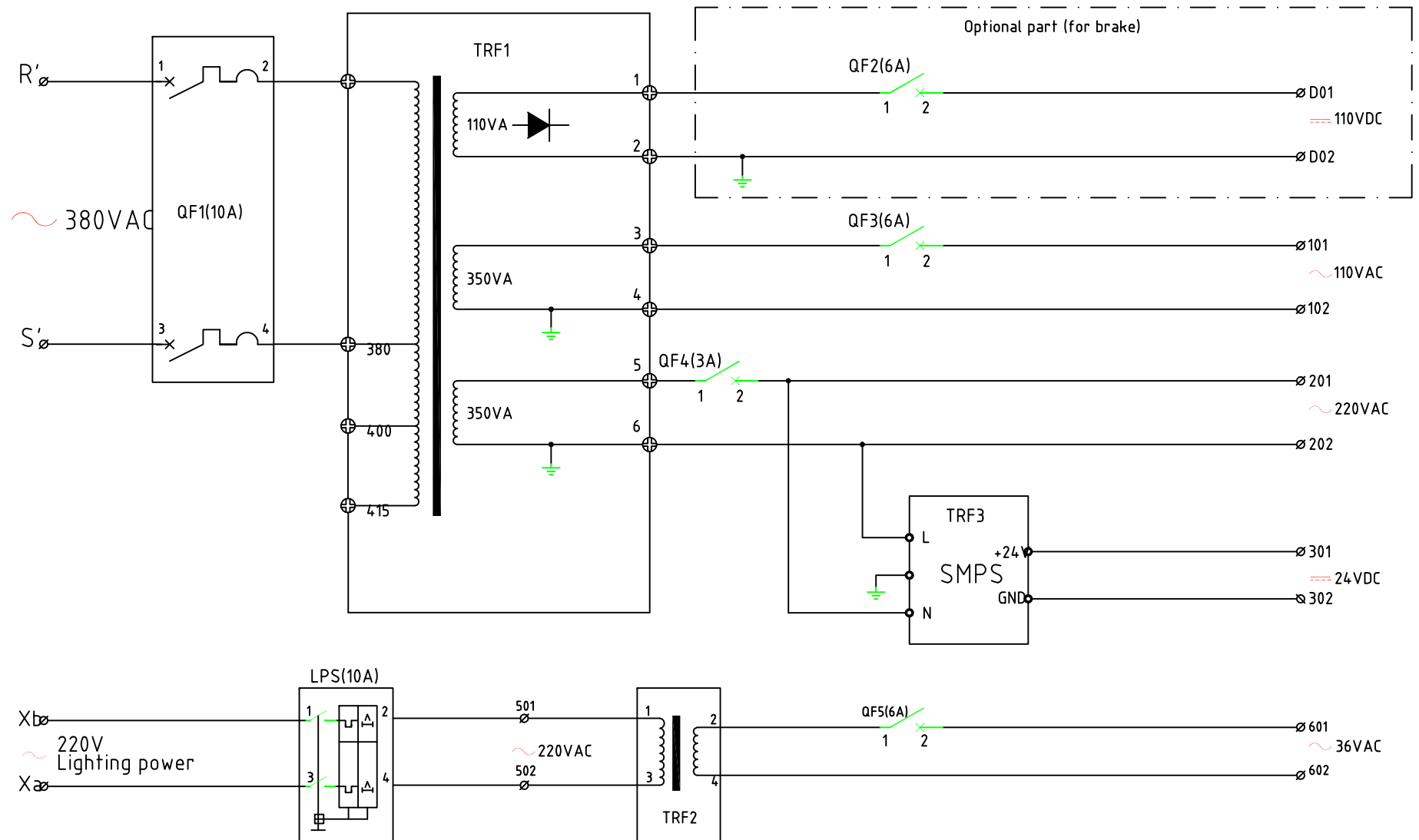

Remark:
 1. When the travelling height less than 10 floors, 5A will be used as the ability of TRF3 SMPS, conversely, 10A will be used.
 3. This power diagram only subject to the case without UPS.

Design	Gaoxiang	SDD		 Suzhou Monarch Control Technology Co., Ltd Page 3 18 Circuit diagram of 380V power supply
CHK	Zhaoqiang			
APPD	Gaoyang			
AUTH	Gaoxiang	Date		

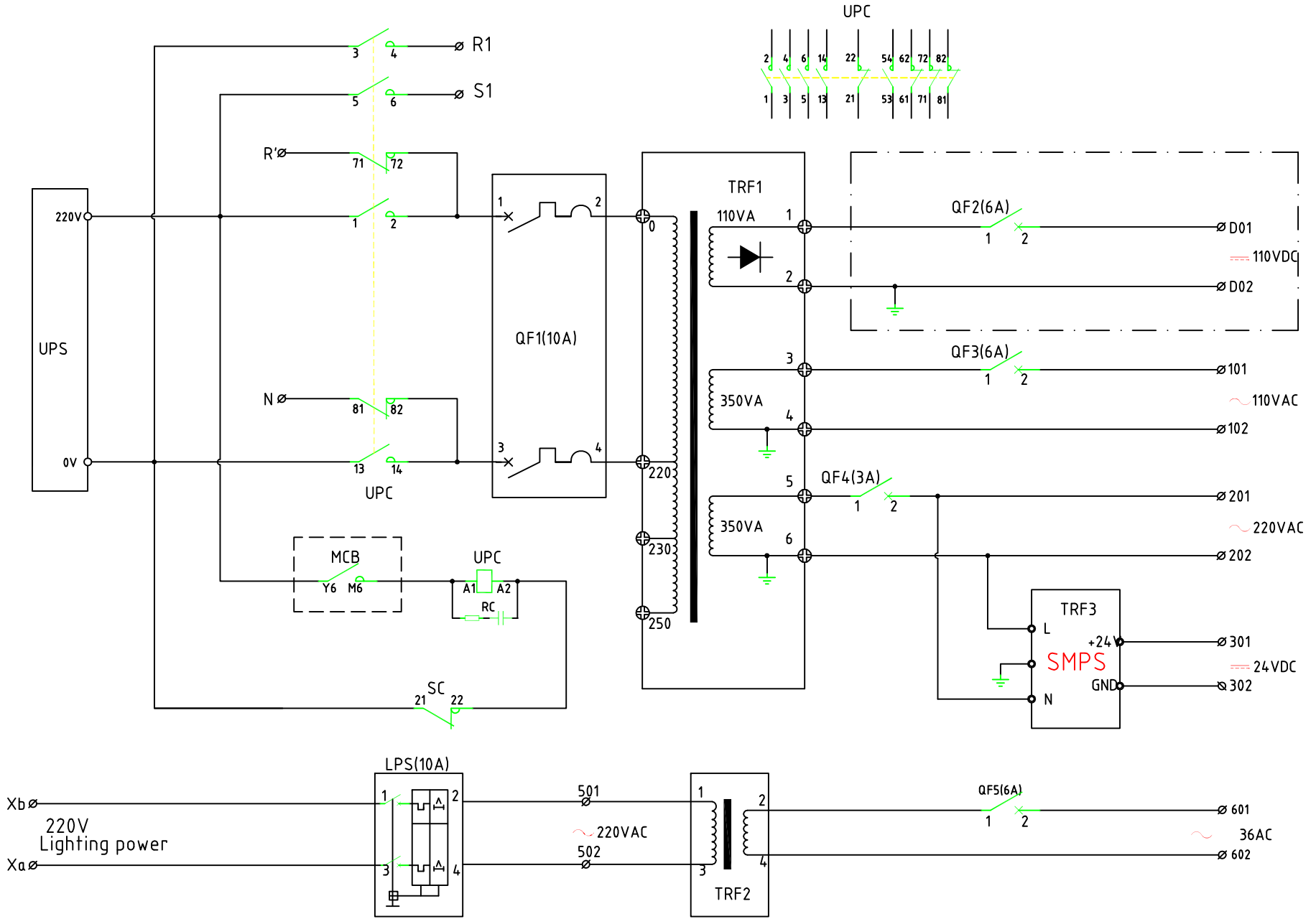

1. When the travelling height less than 10 floors, 5A will be used as the ability of TRF3 10A.
2. PUC adopts AC220V contactor.
3. This circuit apply to the UPS emergency run.

Design	Gaoxiang	SDD		 Suzhou Monarch Control Technology Co., Ltd
CHK	Zhaoqiang			
APPD	Gaoyang		Page 4	
AUTH	Gaoxiang	Date	18	
Circuit diagram of 220V power with UPS emergency power				

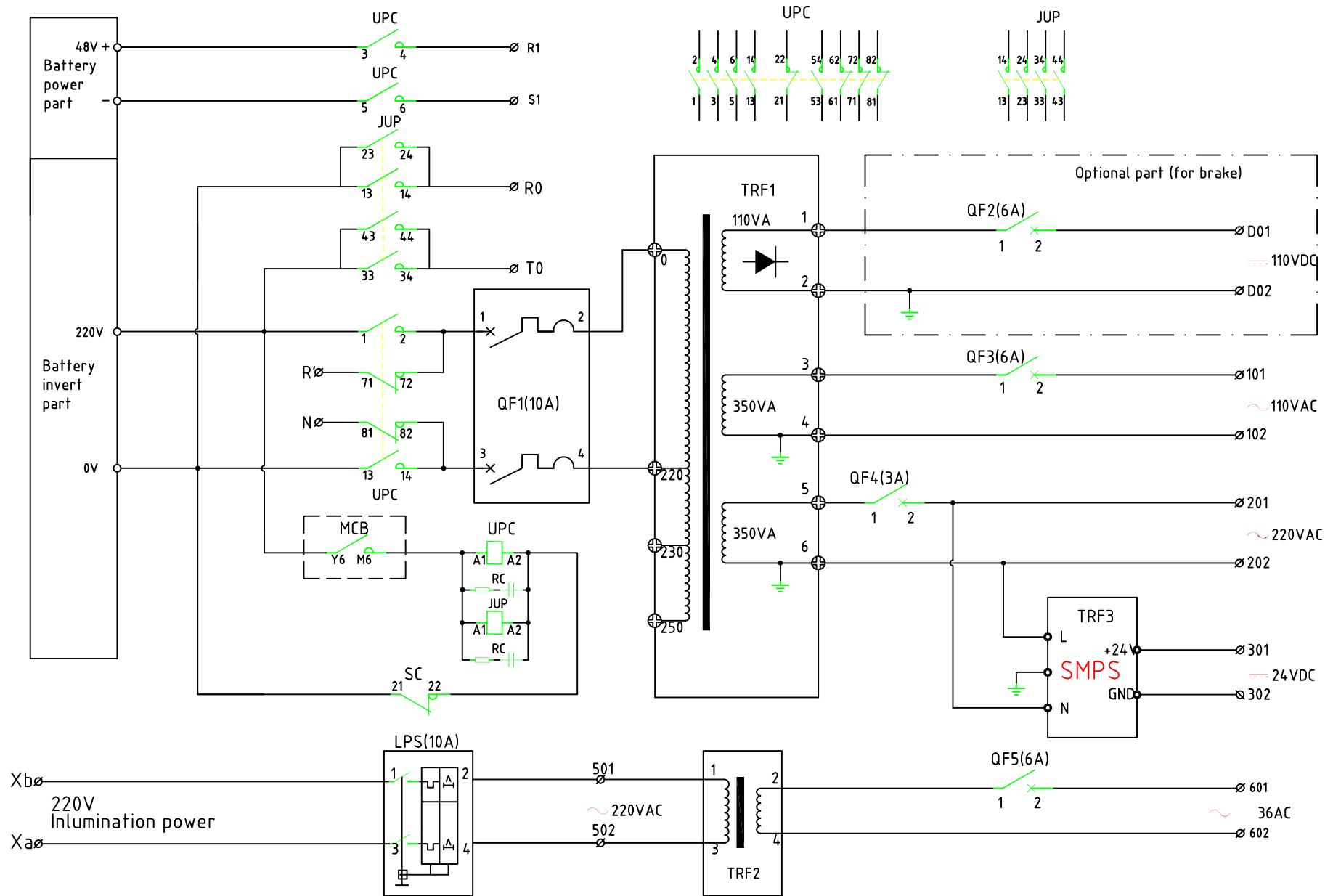

1. When the travelling height less than 10 floors, 5A will be used as the ability of TRF3 10A.
2. UPC, JUP adopt AC220V contactor.
3. This circuit apply to the UPS emergency run.

Design	Gaoxiang	SDD		 Suzhou Monarch Control Technology Co., Ltd
CHK	Zhaoqiang			
APPD	Gaoyang		Page 5	
AUTH	Gaoxiang	Date	18	

Power supply

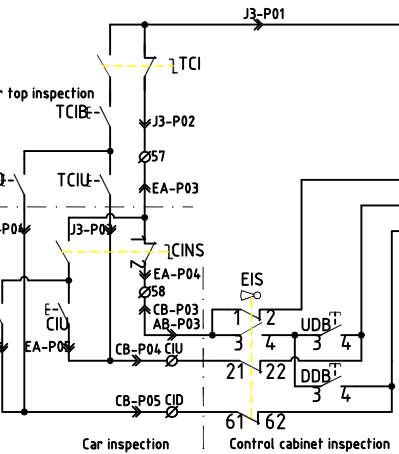
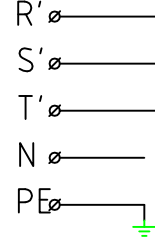

- User needs to provide the suitable TN-S power in accordance with the actual construction conditions.
- The NICE 3000 integrated controller: models that below 30KW (30KW included) have been equipped with standard brake unit. Models that above 37KW (37 kw included) need to be equipped with external brake units.
- Brake resistor model table

Model	Power	Brake resistor
MCTC-DBR-4007	7.5KW	2500W,65Ω
MCTC-DBR-4011	11KW	3500W,43Ω
MCTC-DBR-4015	15KW	4500W,32Ω
MCTC-DBR-4018	18.5KW	5500W,25Ω
MCTC-DBR-4022	22KW	6500W,22Ω
MCTC-DBR-4030	30KW	9000W,16Ω

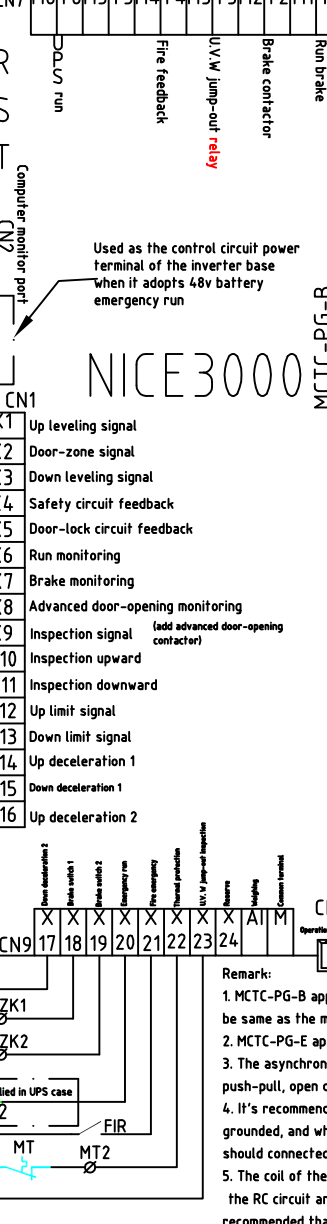
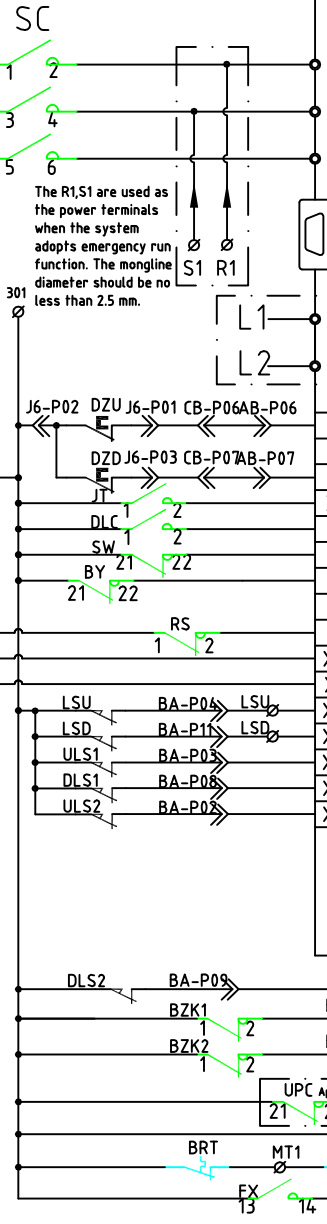

- Remark:
- MCTC-PG-B applies UVW encoder and make sure the pole-pairs should be same as the motor.
 - MCTC-PG-E apply SIN/COS encoder
 - The asynchronous motors apply the incremental encoder with push-pull, open collector output.
 - It's recommended that the encoder shielded wire should be single end grounded, and when the user ground wire is unstable, the shielded wire should connected to the input side PE of the controller.
 - The coil of the AC contactor should be connected to the RC circuit and voltage-sensitive resistor (it's recommended that the voltage-sensitive resistor 110v coil to apply 20k/281, 220v coil apply 20k/481, and the DC relay coil should reversal connect to the diode.

Design	Gaoxiang	SDD	
CHK	Zhaogiang		
APPD	Gaoyang		Page 6
AUTH	Gaoxiang	Date	18

 Suzhou Monarch Control Technology Co.,Ltd
Main control circuit diagram

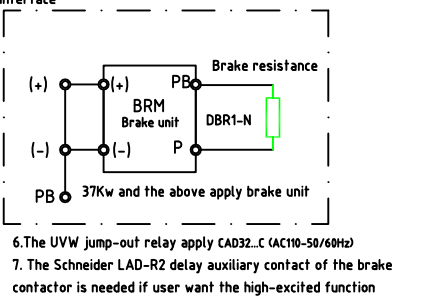
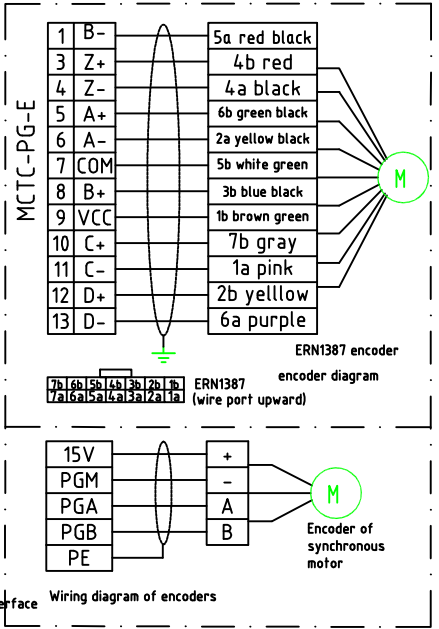

- The UVW jump-out relay apply CAD32.C (AC110-50/60Hz)
- The Schneider LAD-R2 delay auxiliary contact of the brake contactor is needed if user want the high-excited function

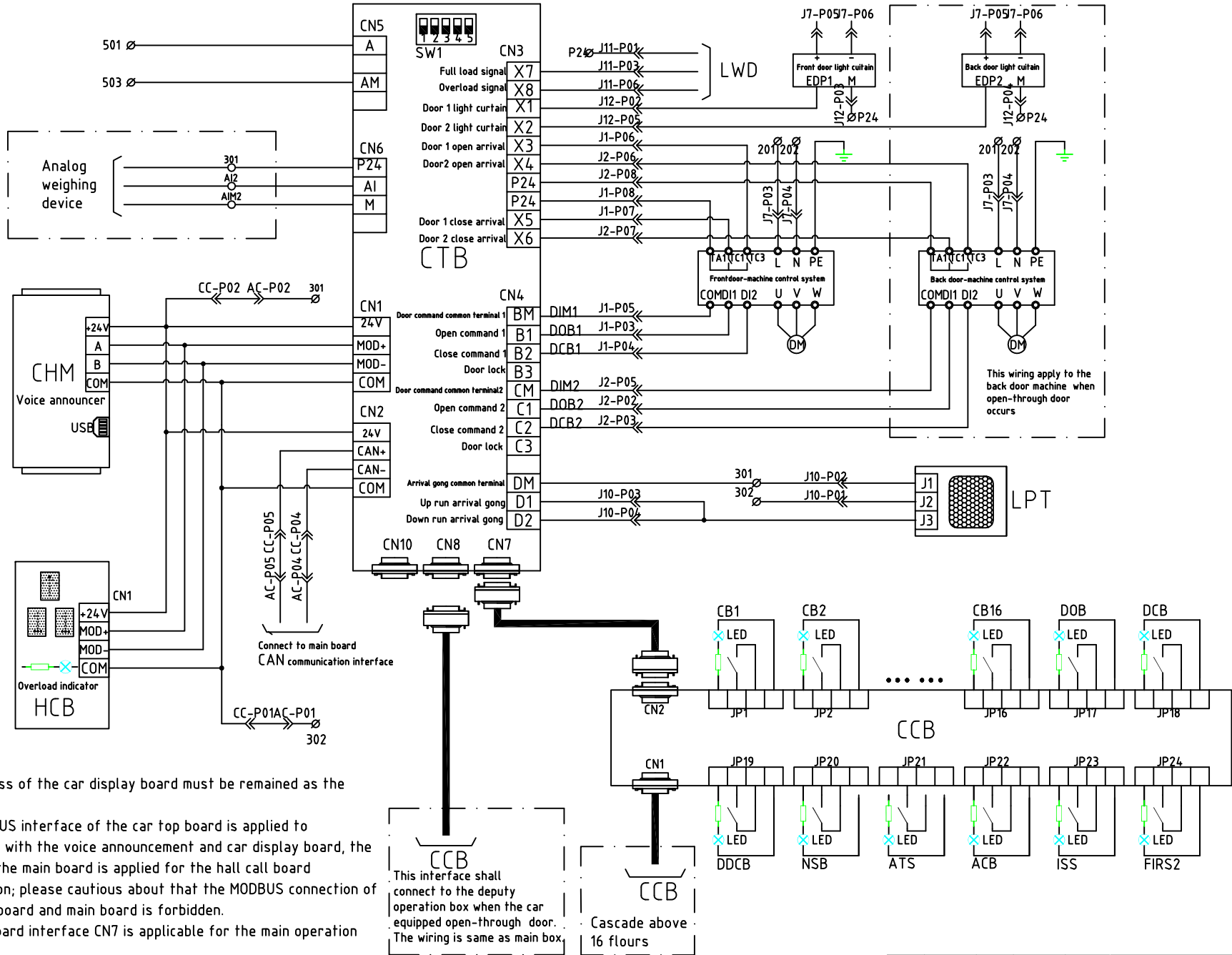

Remark :

1. The address of the car display board must be remained as the default 0.
2. The MODBUS interface of the car top board is applied to communicate with the voice announcement and car display board, the MODBUS of the main board is applied for the hall call board communication; please cautious about that the MODBUS connection of the car top board and main board is forbidden.
3. Car top board interface CN7 is applicable for the main operation box
4. Buttons like open/close, ATT must be connect to the 1st level car call board, the JP 17~JP24 of the cascade car call board are invalid.

CCB
This interface shall connect to the deputy operation box when the car equipped open-through door. The wiring is same as main box.

CCB
Cascade above 16 floors

Design	Gaoxiang	SDD		Monarch Suzhou Monarch Control Technology Co.,Ltd
CHK	Zhaoqiang			
APPD	Gaoyang		Page 7	Car top control circuit diagram
AUTH	Gaoxiang	Date	18	

1#lift

2#lift

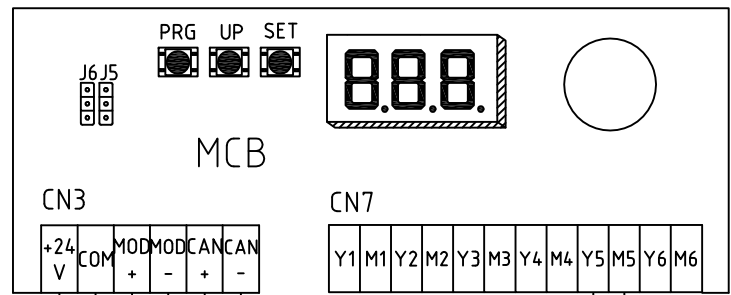
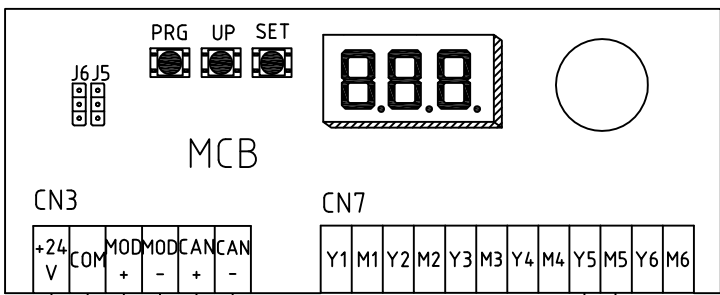

Connect to 1# lift car top CAN interface

Connect to 2# lift car top CAN interface

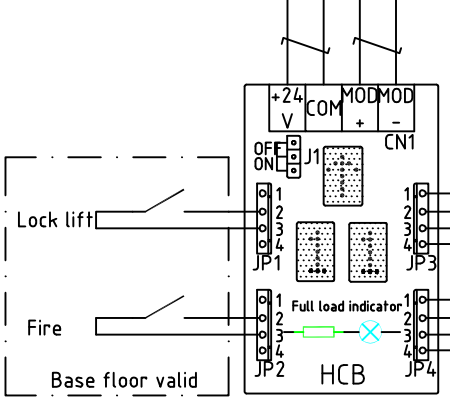

Hall call board

Upward button

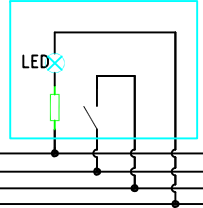

Downward button

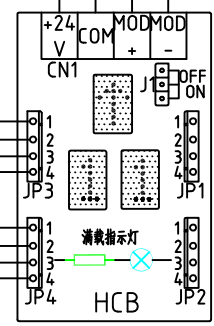
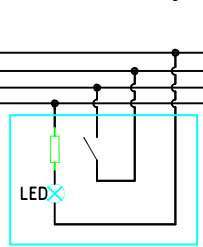

Hall call board

Remark:

1. All the hall call board MODBUS interface should parallel with the main board MODBUS interface; the address of the hall call board should in accordance with the physical address.
2. The bottom display board short J1 (on), the fire emergency, lock-lift switches should install on the corresponding bases, otherwise it will be invalid.
3. Set function code F5-30 (Y5 output function selection) as 14 (parallel); the first bit of the dial switches of lift no. 1 and no.2 are OFF and ON. The 5th are all ON. The J5 on the main board do not need to connect to the terminal resistor.

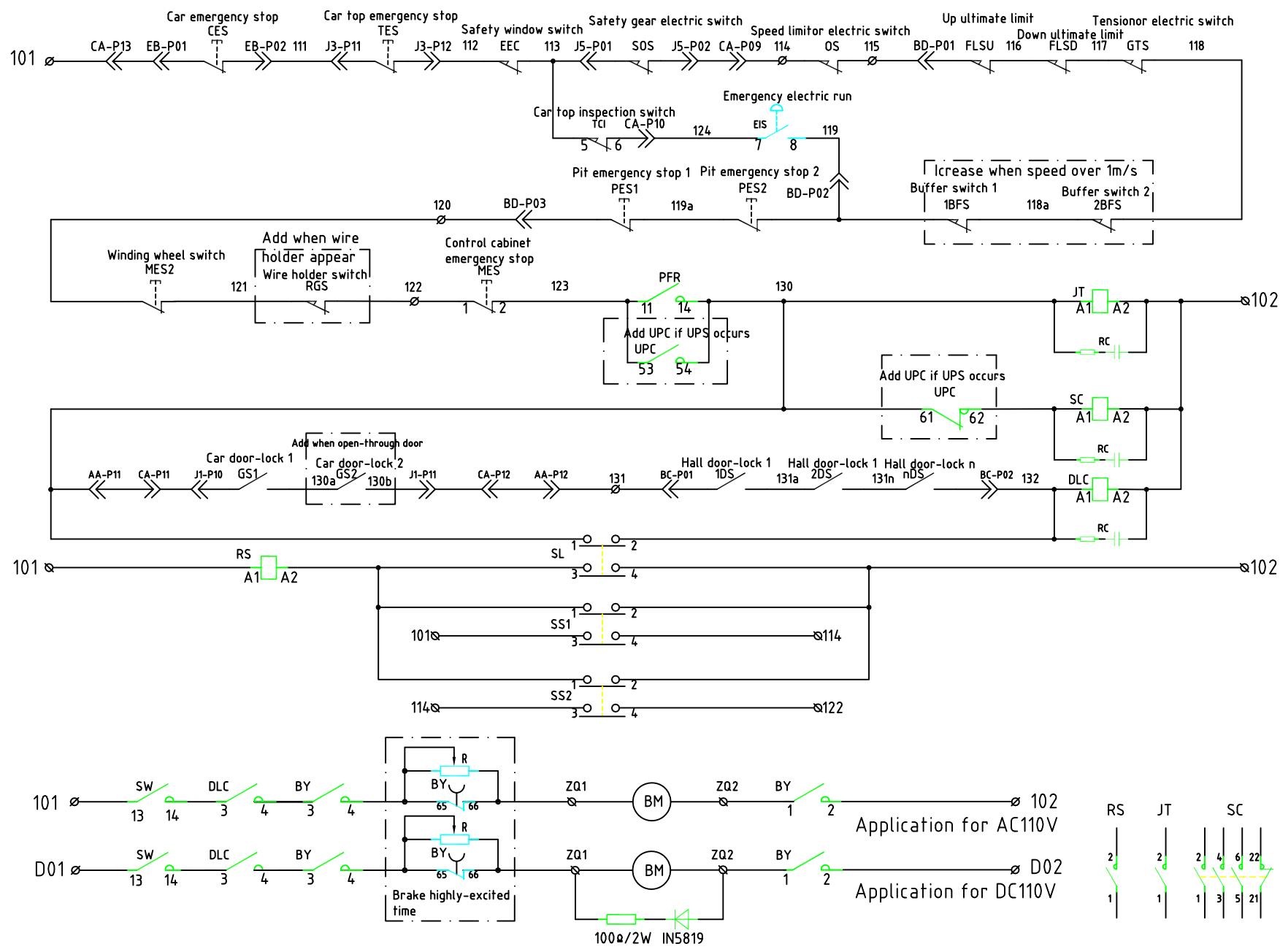

Remark: R stand for sustaining resistor (adopts 100W/100Ω)

Design	Gaoxiang	SDD		Suzhou Monarch Control Technology Co.,Ltd
CHK	Zhaoqiang			
APPD	Goayang		Page 9	Safety braker circuit diagram
AUTH	Gaoxiang	Date	18	

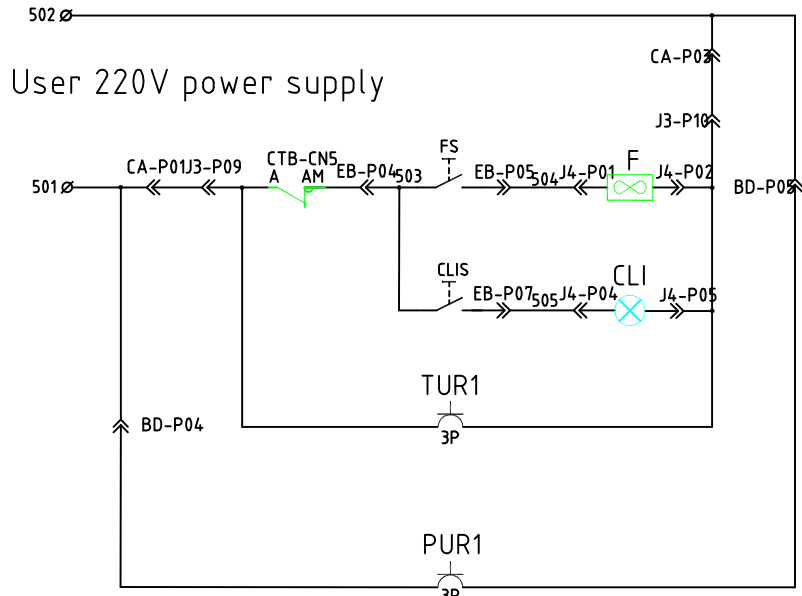

Fan, Light circuit diagram

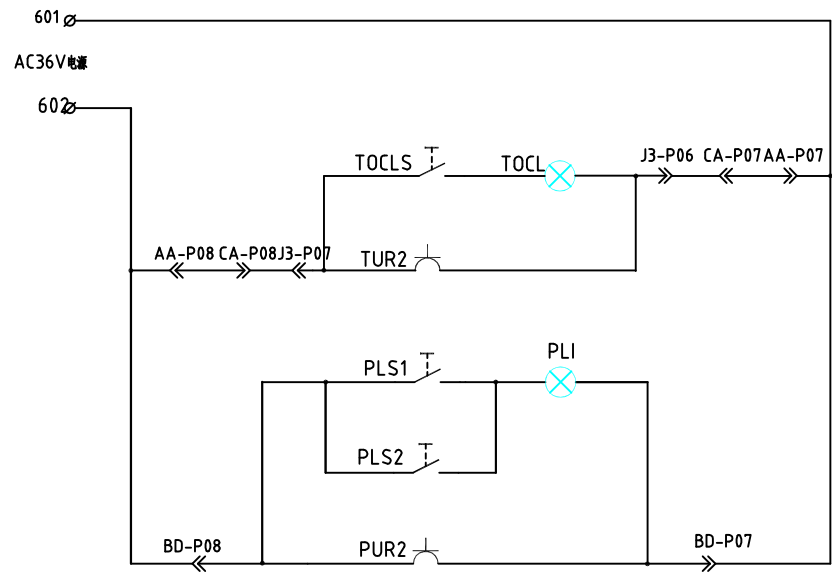

Safety lighting circuit diagram

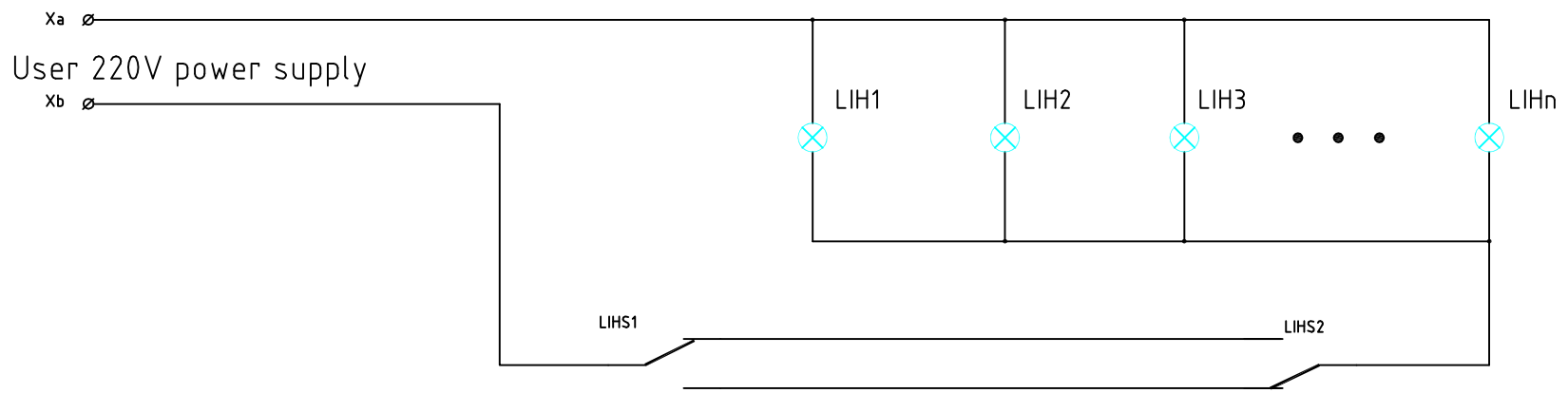

Hoistway lighting circuit diagram

Design	Gaoxiang	SDD		 Suzhou Monarch Control Technology Co.,Ltd
CHK	Zhaoqiang			
APPD	Gaoyang		Page 10	
AUTH	Gaoxiang	Date	18	
				Lighting circuit diagram

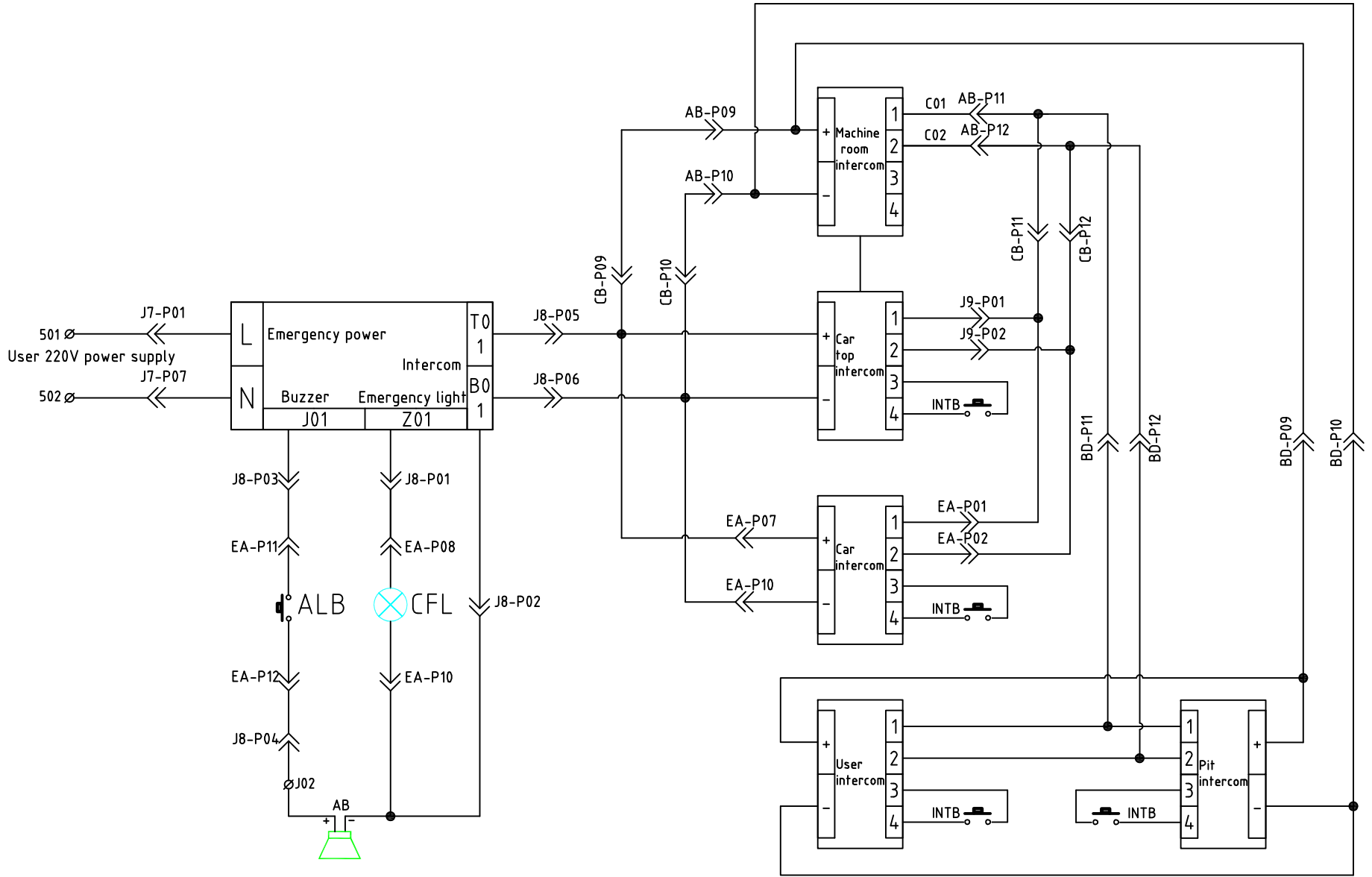

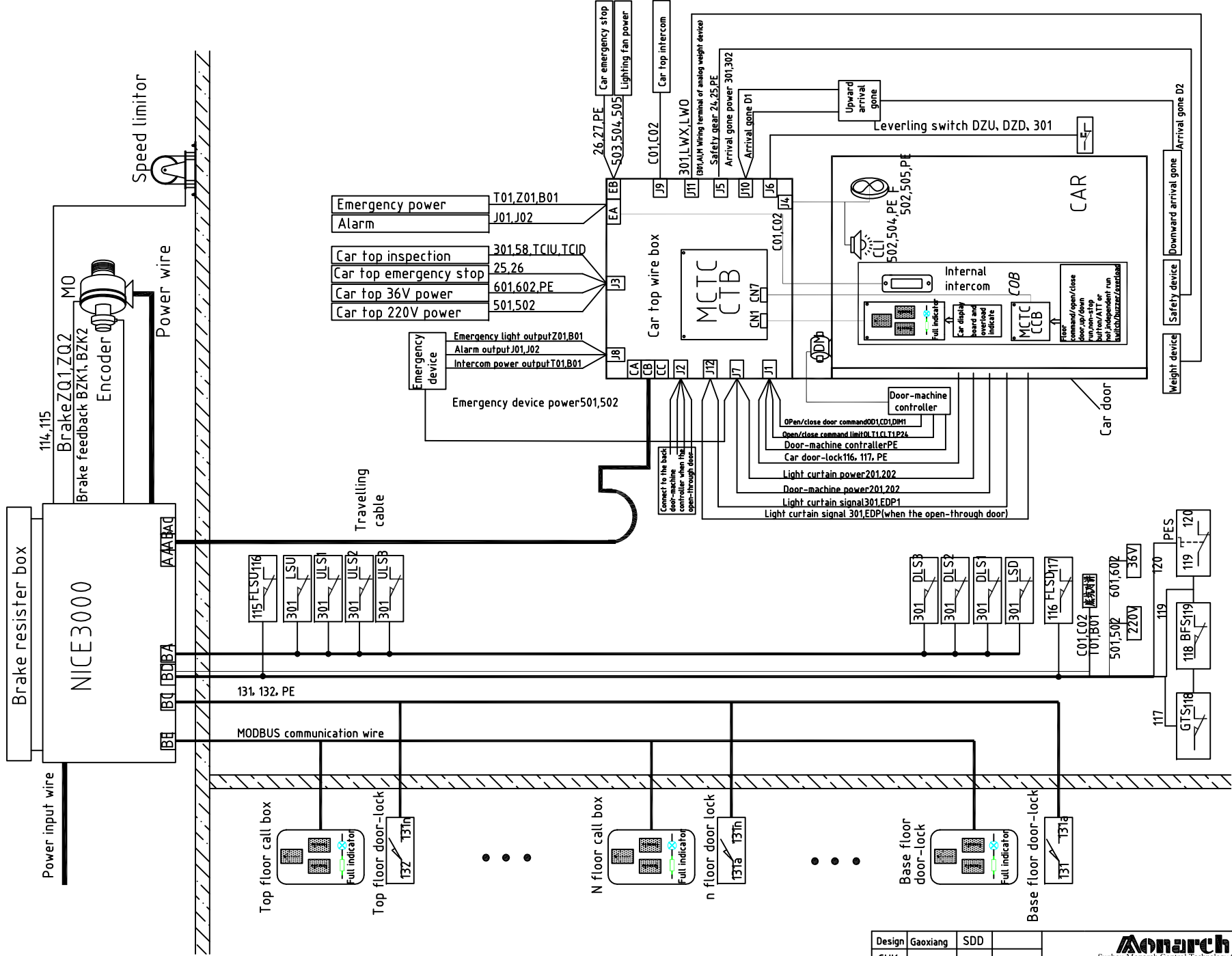

Design	Gaoxiang	SDD		 Suzhou Monarch Control Technology Co., Ltd
CHK	Zhaoqiang			
APPD	Gaoyang		Page 12	
AUTH	Gaoxiang	Date	18	
System diagram				

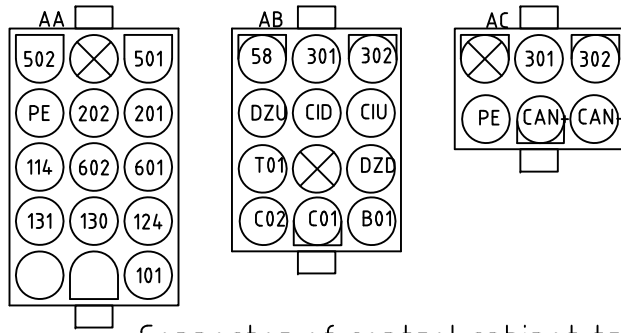

Connector of control cabinet travelling cable

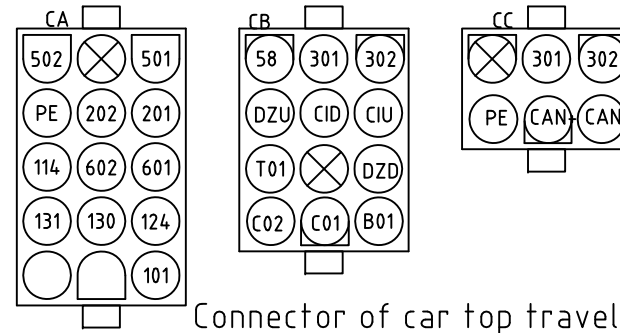

Connector of car top travelling cable

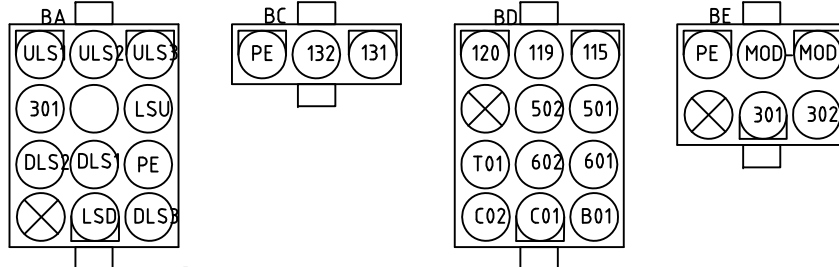

Connector of control cabinet travelling cable

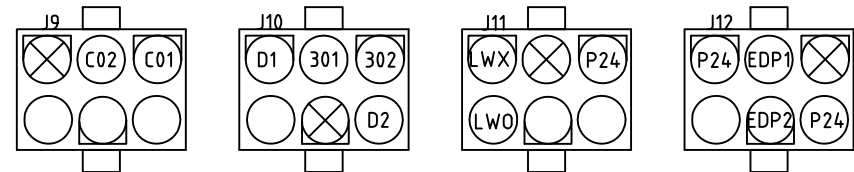
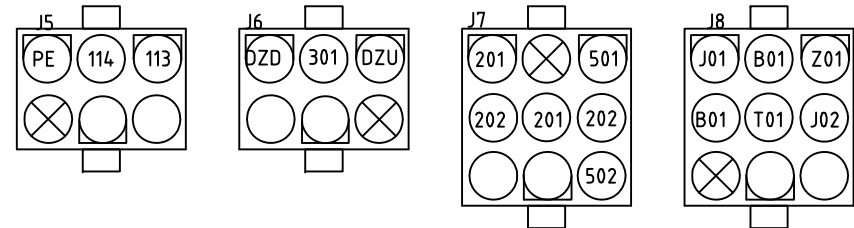
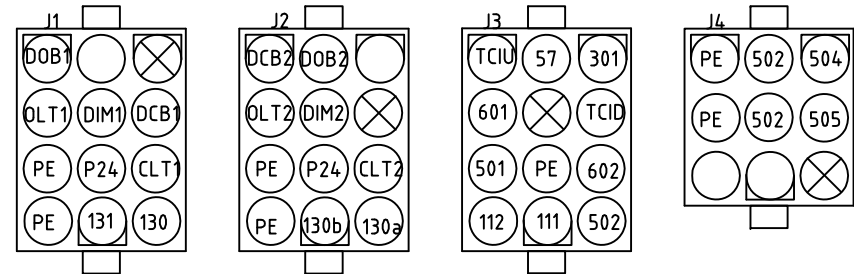

Car top wiring box cable connector

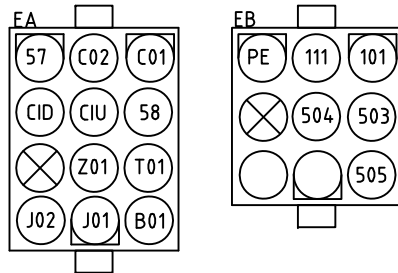

Connector of car operation box cable

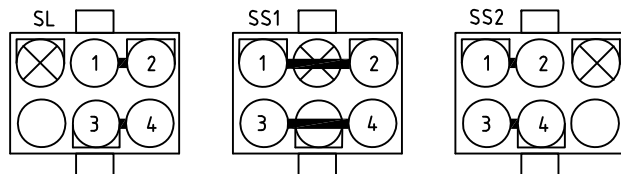

Jump-out plug-in

Remark: ⊗ Connector anti-error method
 ■ Short connection

Plug-in of car top box	Wire NO.	Diagram NO.	Remote terminal	Cable NO.	Remark
J1-P01	1			C5	Wiring of door machine
J1-P02	2				
J1-P03	3	DOB1	Door-open command		
J1-P04	4	DCB1	Door-close command		
J1-P05	5	DIM1	Common terminal of the door open/close command		
J1-P06	6	OLT1	Door-open limit		
J1-P07	7	CLT1	Door-close limit		
J1-P08	8	P24	Common terminal of the door open/close limit		
J1-P09	YellowGreen	PE	Door-machine controller PE		
J1-P10	1	130	Car door lock		
J1-P11	2	131	Car door lock		
J1-P12	YellowGreen	PE	Car door lock grounded		

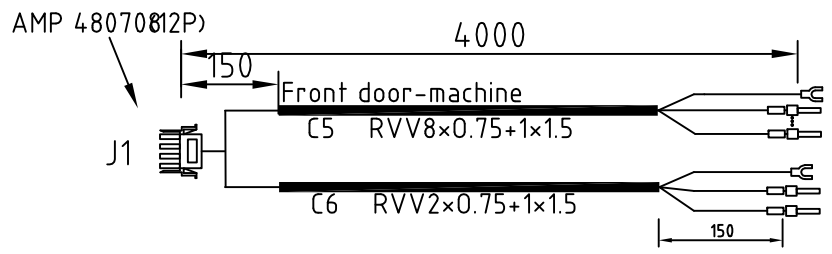

J2-P01	1			C7	Wiring of door machine
J2-P02	2	DOB2	Door-open command		
J2-P03	3	DCB2	Door-close command		
J2-P04	4				
J2-P05	5	DIM2	Common terminal of the door open/close command		
J2-P06	6	OLT2	Door-open limit		
J2-P07	7	CLT2	Door-close limit		
J2-P08	8	P24	Common terminal of the door open/close limit		
J2-P09	YellowGreen	PE	Door-machine controller PE		
J2-P10	1	130a	Car door lock		
J2-P11	2	130b	Car door lock		
J2-P12	YellowGreen	PE	Car door lock grounded terminal		

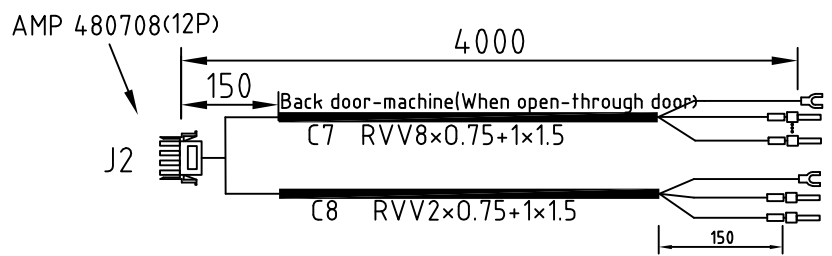

J3-P01	1	301	Car top inspection	C22	Wiring of car top inspection cable
J3-P02	2	57	Car top inspection		
J3-P03	3	CIU	Car top inspection up run		
J3-P04	4	CID	Car top inspection down run		
J3-P05					
J3-P06	11	601	36V power supply		
J3-P07	12	602	36V power supply		
J3-P08	YellowGreen	PE	PE		
J3-P09	5	501	Car top 220V		
J3-P10	6	502	Car top 220V		
J3-P11	7	111	Car top emergency stop		
J3-P12	8	112	Car top emergency stop		

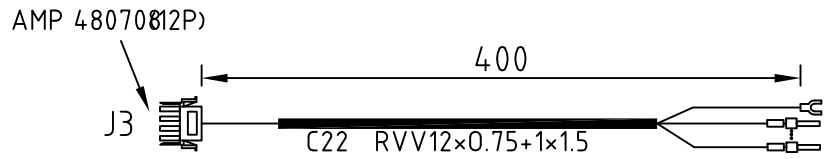

J4-P01	1	504	Car lighting	C11	Wiring of car lighting and fan
J4-P02	2	502	Car lighting		
J4-P03	YellowGreen	PE	Grounded terminal	C12	
J4-P04	1	505	Car fan		
J4-P05	2	502	Car fan		
J4-P06	YellowGreen	PE	Grounded terminal		
J4-P07					
J4-P08					
J4-P09					

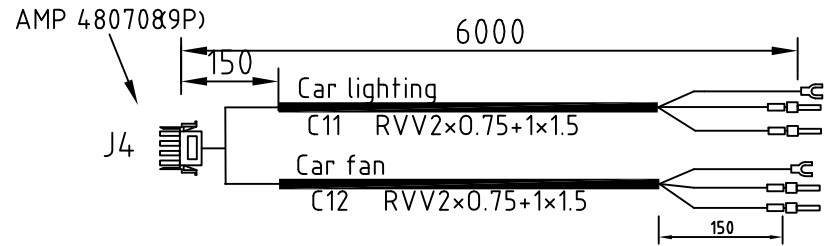

J5-P01	1	113	Safety gear	C13	Wiring of safety gear cable
J5-P02	2	114	Safety gear		
J5-P03	YellowGreen	PE	Grounded wire		
J5-P04					
J5-P05					
J5-P06					

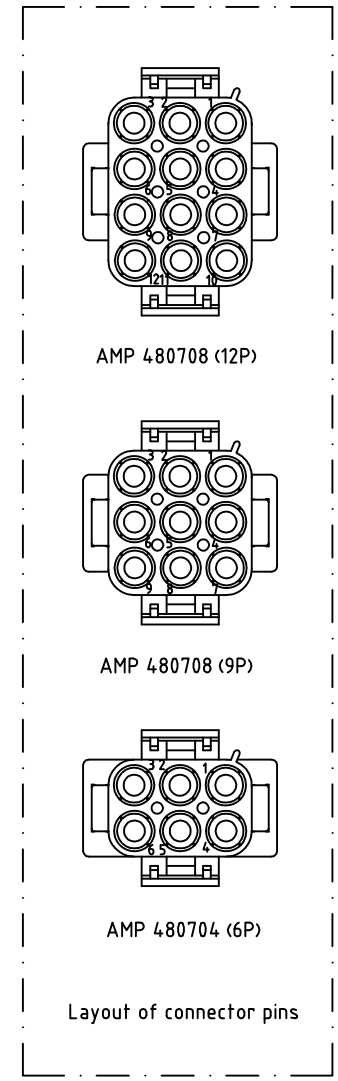
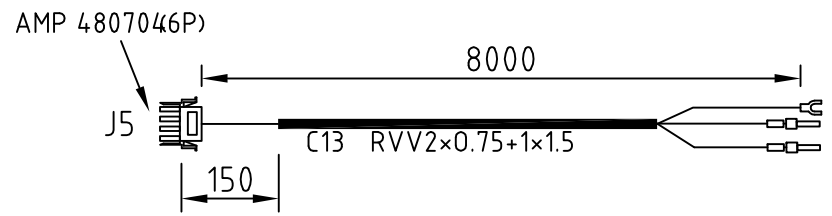

Plug-in of car top box	Wire NO.	Diagram NO.	Remote terminal	Cable NO.	Remark
J6-P01	1	DZU	Up leveling switch	C21	Wiring of door-zone
J6-P02	2	301	Common terminal		
J6-P03	3	DZD	Down leveling switch		
J6-P04	4				
J6-P05	5				
J6-P06	6				
J7-P01	1	501	Power of emergency device	C14	Cable diagram of car top 220V power supply
J7-P02					
J7-P03	3	201	Power of door-machine	C15	
J7-P04	4	202	Power of door-machine	C16	
J7-P05	5	201	Power of light curtain		
J7-P06	6	202	Power of light curtain		
J7-P07	7	502	Power of emergency device	C14	
J7-P08	8				
J7-P09	9				
J8-P01	1	Z01	Emergency light output	C17	Emergency device cable diagram
J8-P02	2	B01	Emergency light output		
J8-P03	3	J01	Alarm output		
J8-P04	4	J02	Alarm output		
J8-P05	5	T01	Intercom power output		
J8-P06	6	B01	Intercom power output		
J8-P07					
J8-P08					
J8-P09					
J9-P01	1	C01	Car top interphone signal	C18	Cable diagram of car top intercom
J9-P02	2	C02	Car top interphone signal		
J9-P03					
J9-P04					
J9-P05					
J9-P06					
J10-P01	1	302	Power of arrival gong -	C19	Cable diagram of arrival gong
J10-P02	2	301	Power of arrival gong +		
J10-P03	3	D1	Up arrival gong		
J10-P04	4	D2	Down arrival gong		
J10-P05					
J10-P06					
J11-01	1	301	Common end of full/overload	C20	Choose when diagram of arrival gong
J11-02	2				
J11-03	3	LWX	Full		
J11-04	4				
J11-05	5				
J11-06	6	LWO	Overload		
J11-01	1	P24	Power of weighing switch	C20	Choose when analog weighing
J11-02	2	AI	Signal of weighing switch		
J11-03	3	M	Signal of weighing switch		
J11-04					
J11-05					
J11-06					

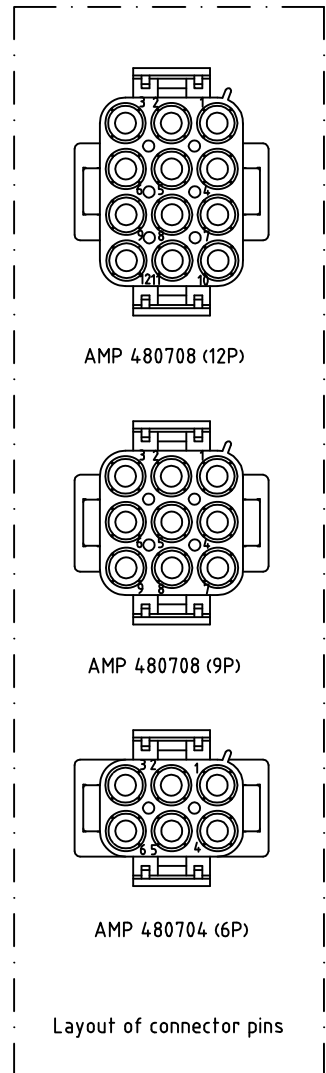
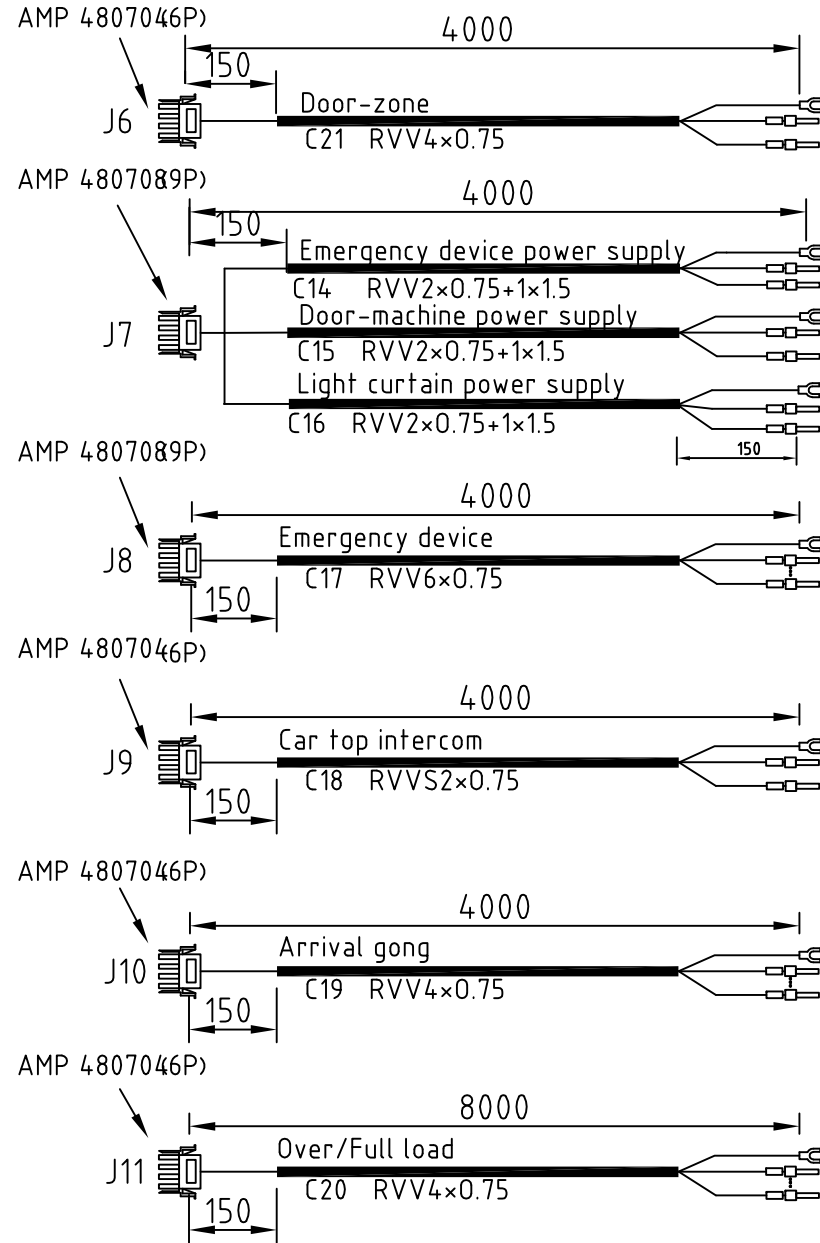

	Plug-in of car top box	Wire NO.	Diagram NO.	Remote terminal	Cable NO.	Remark
J12	J12-P01	1		Signal of front door light curtain	C9	Cable wiring of curtain
	J12-P02	2	EDP1	Common terminal of light curtain		
	J12-P03	3	P24	Common terminal of light curtain	C10	
	J12-P04	4	P24	Common terminal of light curtain		
	J12-P05	5	EDP2	Signal of back door light curtain		
	J12-P06	6				

	Plug-in of car top box	Wire NO.	Diagram NO.	Remote terminal	Cable NO.	Remark
EA	EA-P01	1	C01	Signal of car intercom	C2	Cable wiring of COP
	EA-P02	2	C02	Signal of car intercom		
	EA-P03	3	57	Inspection signal		
	EA-P04	4	58	Inspection signal 1		
	EA-P05	5	CIU	Car inspection up run		
	EA-P06	6	CID	Car inspection down run		
	EA-P07	7	T01	Power supply of intercom		
	EA-P08	8	Z01	Power supply of emergency light		
	EA-P09	9				
	EA-P10	10	B01	Common terminal of emergency light		
	EA-P11	11	J01	Alarm button		
	EA-P12	12	J02	Alarm button		
EB	EB-P01	1	101	Car top emergency stop	C2a	
	EB-P02	2	111	Car top emergency stop		
	EB-P03	YellowGreen	PE	Grounded terminal		
	EB-P04	4	503	Power supply of lighting and fan		
	EB-P05	5	504	Fan		
	EB-P06	6				
	EB-P07	7	505	Lighting		
	EB-P08	8				
	EB-P09	9				

Hole NO. of the car top side connector	Wire NO.	Diagram NO.	Function	Hole NO. of the car top side connector	Wire NO.
CTB:CN1.2	Yellow 1	CMD+	MOD communication signal +	HCB:CN1.2	C2b
CTB:CN1.3	Yellow 2	CMD-	MOD communication signal -	HCB:CN1.3	
CTB:CN1.1	White 1	301	Power supply of communications	HCB:CN1.1	
CTB:CN1.4	White 2	302	Power supply of communication-	HCB:CN1.4	
CTB:CN7	Car call board special connect cable MCTC-CCL			CCB:CN2	

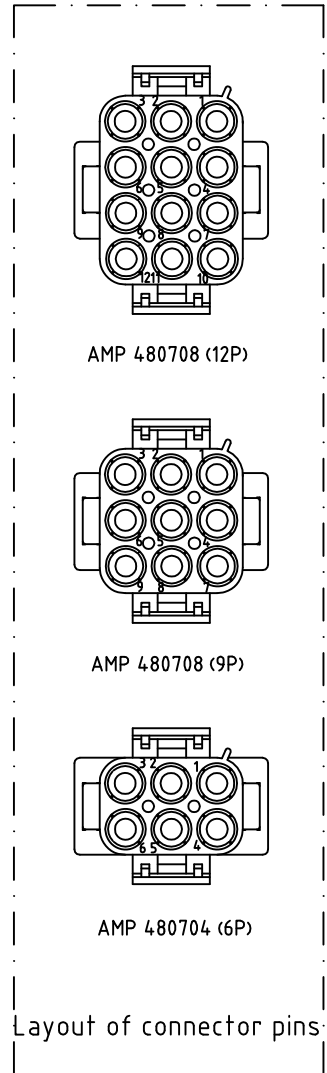
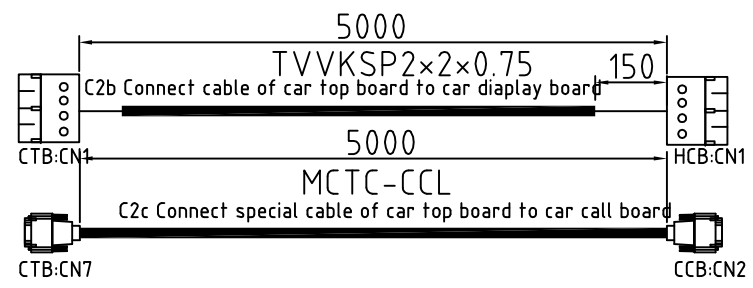
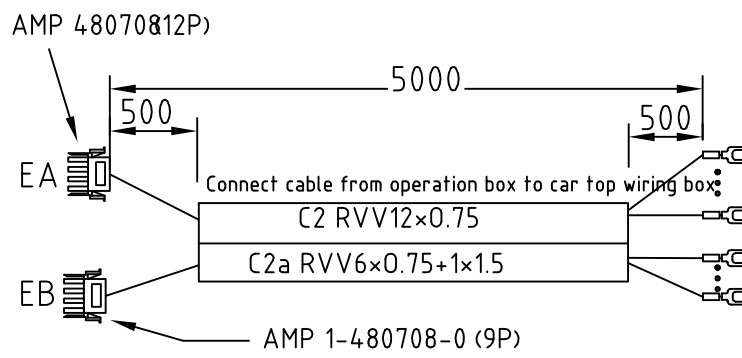
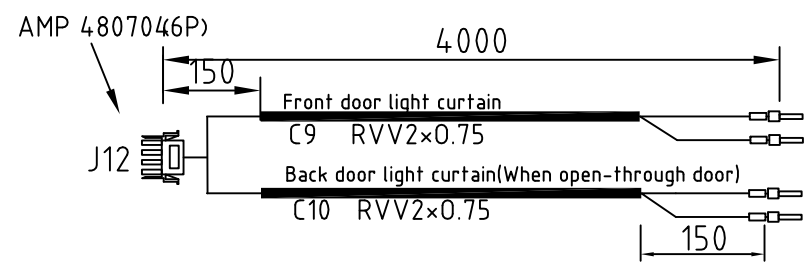

Plug-in of control cabinet	Wire NO.	Diagram NO.	Remote terminal	Cable NO.	Remark
BE-P01	Yellow1	MOD+	HCB:CN2	C21	Wiring of hoistway communication cable
BE-P02	Yellow2	MOD-	HCB:CN3		
BE-P03	shielded	PE	Grounded terminal		
BE-P04	White1	302	HCB:CN4		
BE-P05	White2	301	HCB:CN1		
BE-P06					
BE-P07					
BE-P08					
BE-P09					

Plug-in of control cabinet	Wire NO.	Diagram NO.	Remote terminal	Cable NO.	Remark
BA-P01	1	ULS3	3rd up forced slowdown	C3	Switch bracket wiring cable table
BA-P02	2	ULS2	2nd up forced slowdown		
BA-P03	3	ULS1	1st up forced slowdown		
BA-P04	4	LSU	Up limit		
BA-P05					
BA-P06	6	301	Common terminal		
BA-P07	7	PE	Grounded terminal		
BA-P08	8	DLS1	1st down forced slowdown		
BA-P09	9	DLS2	2nd down forced slowdown		
BA-P10	10	DLS3	3rd down forced slowdown		
BA-P11	11	LSD	Down limit		
BA-P12	12				

Plug-in of control cabinet	Wire NO.	Diagram NO.	Remote terminal	Cable NO.	Remark
BC-P01	1	131	Hall gate lock	C25	Hall gate lock cable wiring table
BC-P02	2	132	Hall gate lock		
BC-P03	Yellow/Green	PE	Grounded terminal		
BC-P04	4				
BC-P05					
BC-P06					
BC-P07					
BC-P08					
BC-P09					

Plug-in of control cabinet	Wire NO.	Diagram NO.	Remote terminal	Cable NO.	Remark
BD-P01	1	115	Pit safety	C23	Pit cable wiring table
BD-P02	2	119	Emergency power-driven		
BD-P03	3	120	Pit safety		
BD-P04	4	501	Pit socket		
BD-P05	5	502	Pit socket		
BD-P06	6				
BD-P07	7	601	Pit safety power supply		
BD-P08	8	602	Pit safety power supply		
BD-P09	9	T01	Pit intercom power supply		
BD-P10	10	B01	Pit intercom power supply		
BD-P11	11	C01	Pit intercom		
BD-P12	12	C02	Pit intercom		

Remark :
 Skin 300mm of cable at machine room terminal
 brach termination skin 200mm.Breach to switch
 4m line ,skin 200mm,connection using
 press&connection hat.

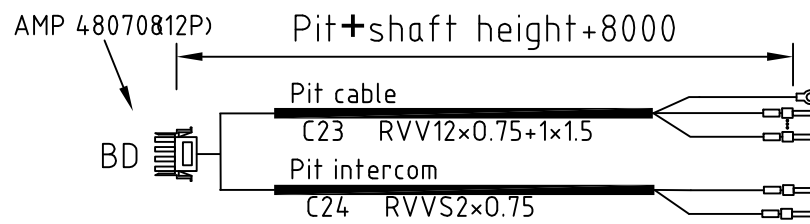
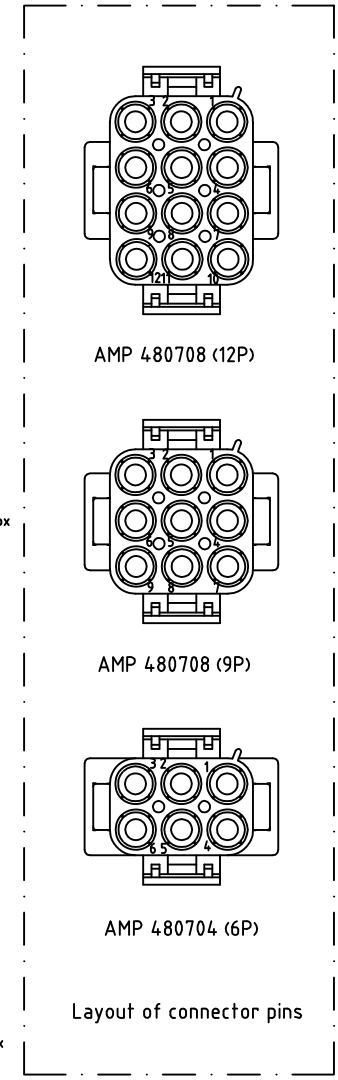
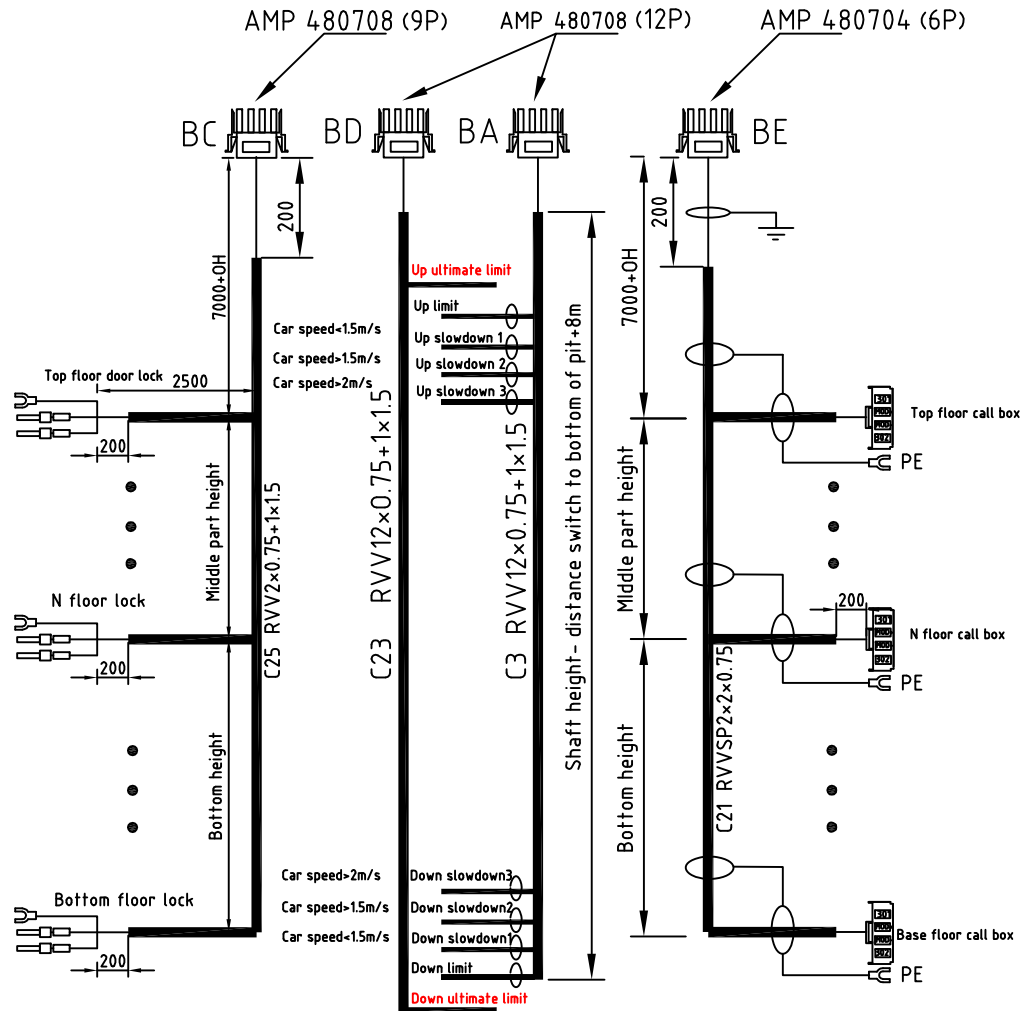
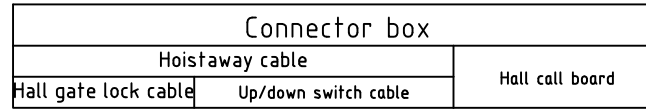

{With machine room:13M+Hoistway height(TH)}{Underlying machine room:16M+Hoistway height(TH)}{Machine room-less8M+Hoistway height(TH)}

C1				
TVVBP 30×0.75+(2×2P)×0.75				
Plug-in of car top box	Wire NO.	Diagram NO.	Plug-in of car top	
AA-P01	Yellow1	501	CA-P01	C A
AA-P02			CA-P02	
AA-P03	Yellow2	502	CA-P03	
AA-P04	Yellow3	201	CA-P04	
AA-P05	Yellow4	202	CA-P05	
AA-P06	Yellow5	PE	CA-P06	
AA-P07	Yellow6	601	CA-P07	
AA-P08	Yellow7	602	CA-P08	
AA-P09	Yellow8	114	CA-P09	
AA-P10	Yellow9	124	CA-P10	
AA-P11	Yellow10	130	CA-P11	
AA-P12	White1	131	CA-P12	
AA-P13	White2	101	CA-P13	

A B				
AB-P01	White6	302	CB-P01	C B
AB-P02	White7	301	CB-P02	
AB-P03	White8	58	CB-P03	
AB-P04	White9	TCIU	CB-P04	
AB-P05	White10	TCID	CB-P05	
AB-P06	White1	DZU	CB-P06	
AB-P07	White2	DZD	CB-P07	
AB-P08			CB-P08	
AB-P09	White3	T01	CB-P09	
AB-P10	White4	B01	CB-P10	
AB-P11	White5	C01	CB-P11	
AB-P12	White6	C02	CB-P12	

A C				
AC-P01	Shielded wire 1	302	CC-P01	C C
AC-P02	Shielded wire 2	301	CC-P02	
AC-P03			CC-P03	
AC-P04	Shielded wire 3	CAN-	CC-P04	
AC-P05	Shielded wire 4	CAN+	CC-P05	
AC-P06	Shielded level	PE	CC-P06	

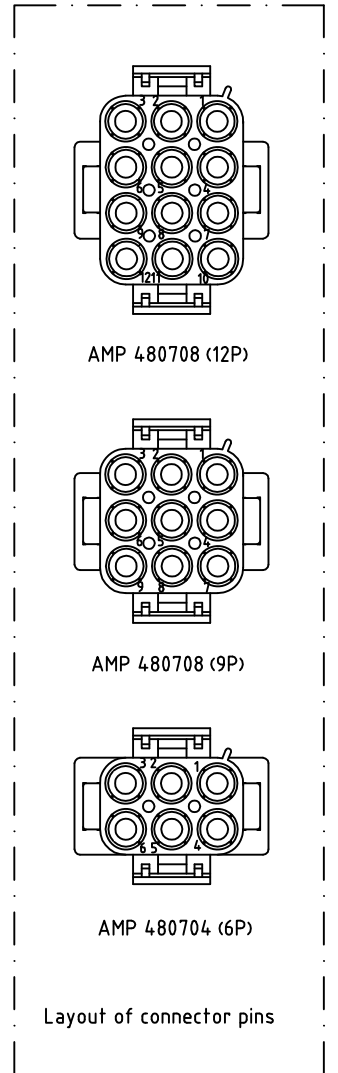
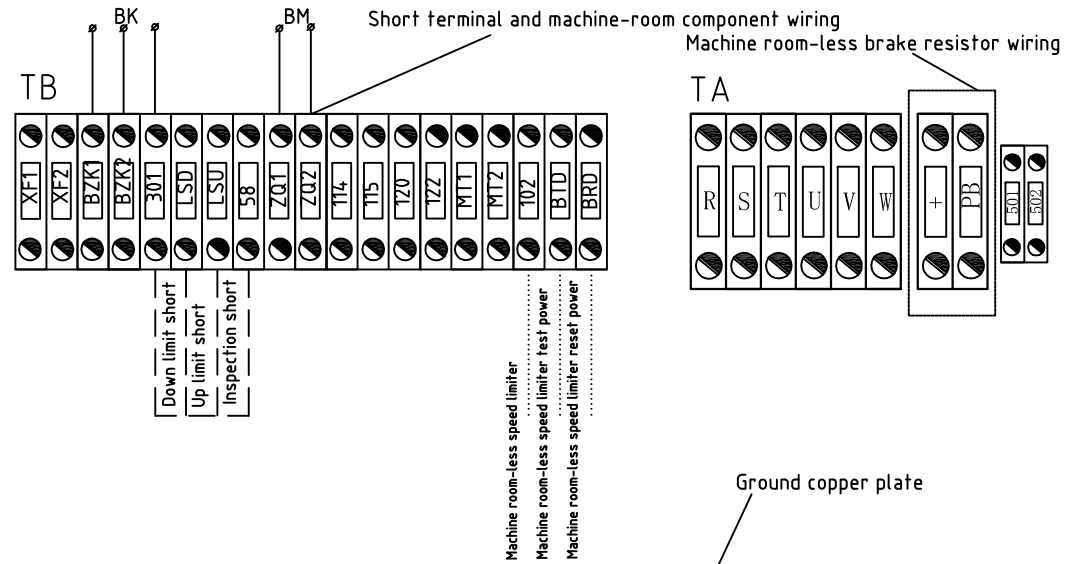
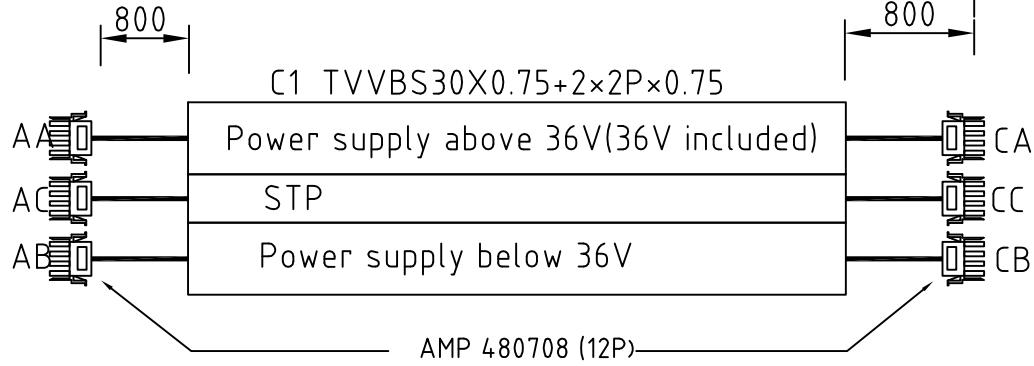

Annex: Connect diagram of machine room-less speed limiter

